



Capitol Lighting Plastics

Vaportite Drops & Assemblies



Vaportite Housing & Lens for 2 Light Strip Fixtures

Our Vaportite enclosures for fluorescent strip fixtures are composed of a fiberglass upper housing and acrylic diffuser held with retaining latches against a weatherproof neoprene seal. Suitable for use in wet and damp locations it is ideal for exterior applications as well as food service areas.

Fixture & lamps are not included

Part Number	Description	Length
GVT-224-0002	Housing and Diffuser for 2 light strip fixture	4 Foot
GVT-296-0002	Housing and Diffuser for 2 light strip fixture	8 Foot
GVT241-3300	Diffuser Only For Assembly	4 Foot
GVT2973300	Diffuser Only for Assembly	8 Foot



Replacement Rolled Flange Drop Diffuser for Vaportite Fixtures

Part Number	Description	Width	Length
GVT-241-3300	Matte Finish Acrylic	7.25"	49.625"
GVT-240-3300	Matte Finish Acrylic	7.25"	51.75"
GVT-242-3301	Clear Prism Acrylic Pattern 12	7"	51.5"
GVT-296-3300	Matte Finish Acrylic	7.25"	102"
GVT-297-3300	Matte Finish Acrylic	7.25"	97.75"

Above Parts are 2.25" Deep

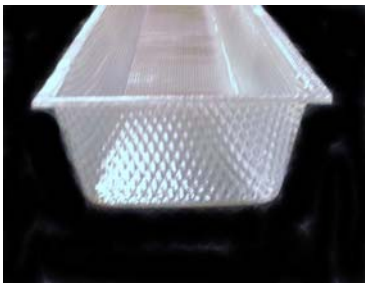

Replacement Flat Flanged Drop Diffuser for Vaportite Fixtures

Part Number	Min Width	Min Length	Max Width	Max Length
GVT-240-1100	7.625"	49.75"	7.875"	50.25"
GVT-240-1700	7.25"	49.375"	7.75"	49.75"
GVT-296-1100	7.625"	97.75"	7.875"	98.187"
GVT-296-1700	7.25"	97.5"	7.625"	98.312"
GVT-440-1100	11.75"	50"	11.875"	50.25"

Above parts are 3" Deep



Capitol Lighting Plastics, Inc.

Double Seal E & G Vaportite Specification Sheet

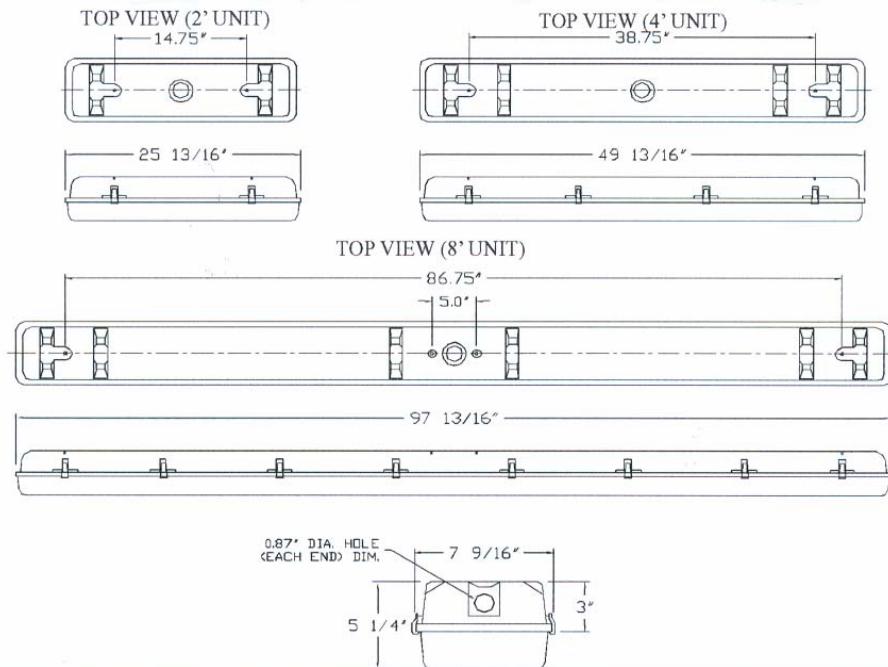

Weather resistant and corrosion free fiberglass units with no exposed metal parts are suitable for; • exterior applications, • food processing areas, • environments where water vapor or high humidity are present. Fire retardant housing is molded from glass (22%) reinforced polyester resin.

Matte or prismatic lens diffusers (standard material - Acrylic+DR) seat into a continuously poured in place gasket and are secured by 4 (2 ft.), 8 (4 ft.), or 16 (8 ft.) plastic cam latches.

With a U.L. recognized strip light fixture, the assembly has been approved and listed by U.L. as suitable for use in wet and damp locations. Contact American Louver for information on a

multiple listing. **Approvals and Listings:** • IP65  **• Underwriters Laboratories • National Sanitation Foundation • Canadian Stds. Assoc. • Prismatic Lens Diffuser – Patent Pending**

◀ Features ▶

Body • HD one piece • High impact glass reinforced polyester • U.L. rec. fire retard. mtl. • Brass studs
Lens Diffuser • Injection molded acrylic + DR blend or polycarbonate • Double sealing ridges on flange
Gasketing • Odor free • Non-toxic • Fire retardant • Poured in place



Capitol Lighting Plastics

VAPOR STYLE DROP DIFFUSER

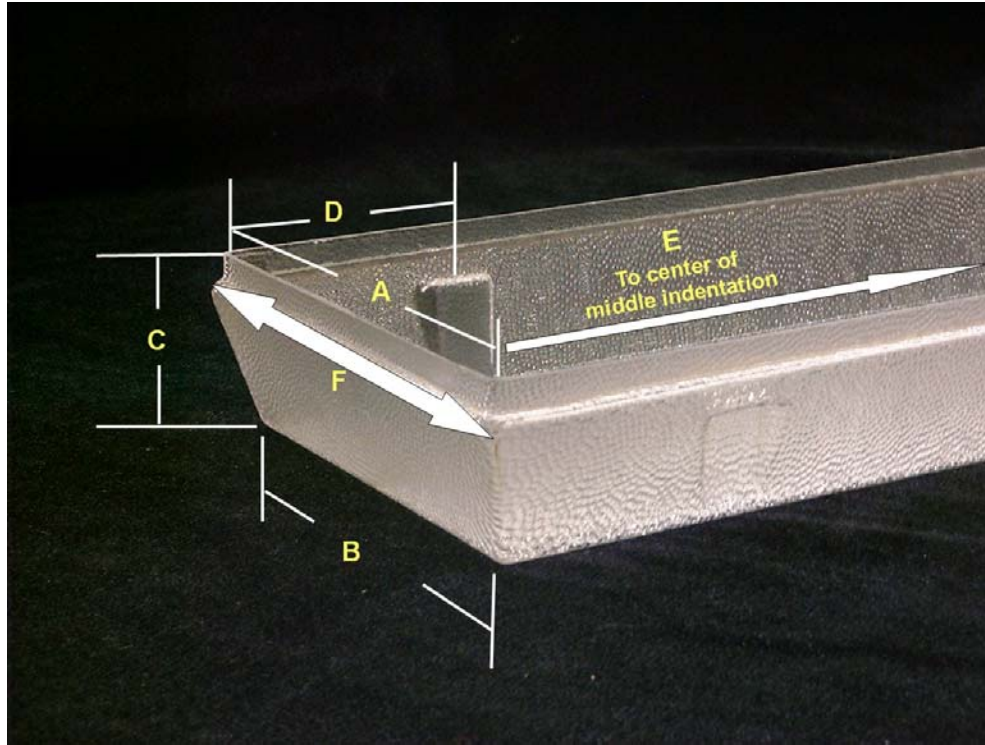

ID # 91405-1535

- A: Width: 6 - 11/16" Length: 50"
- B: Width: 6 - 1/8" Length: 49 - 3/8"
- C: Depth: 2 - 1/4"
- D: Center of notch from each end: 3 - 1/2"
- E: Center of middle notch from end: 25"
- F: Width: 7" Length: 50 - 1/4"

ID # 91305-1250

- A: Width: 6 - 5/8" Length: 50 - 1/2"
- B: Width: 6 - 1/4" Length: 49 - 3/4"
- C: Depth: 2"
- D: Center of notch from each end: 3 - 1/4"
- E: Center of middle notch from end: 25 - 1/4"
- F: Width: 7 - 1/4" Length: 51"